

Nexus Mudroom Cabinet

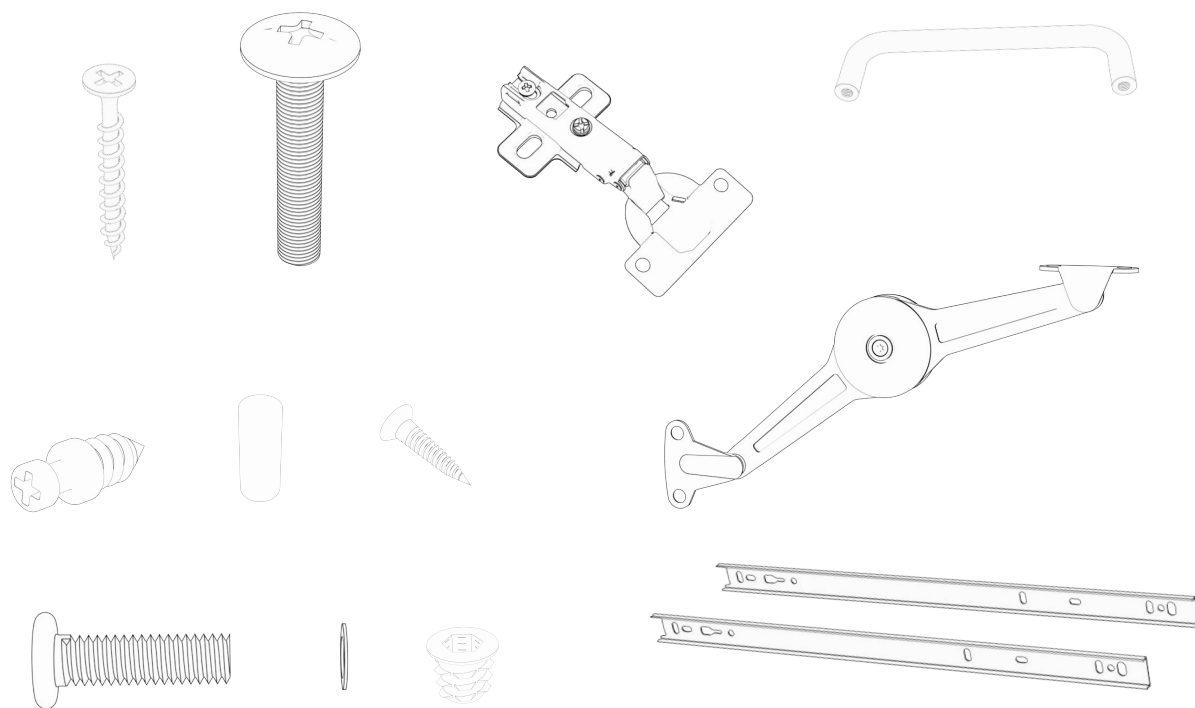

Assembly Hardware



Recommended Tools

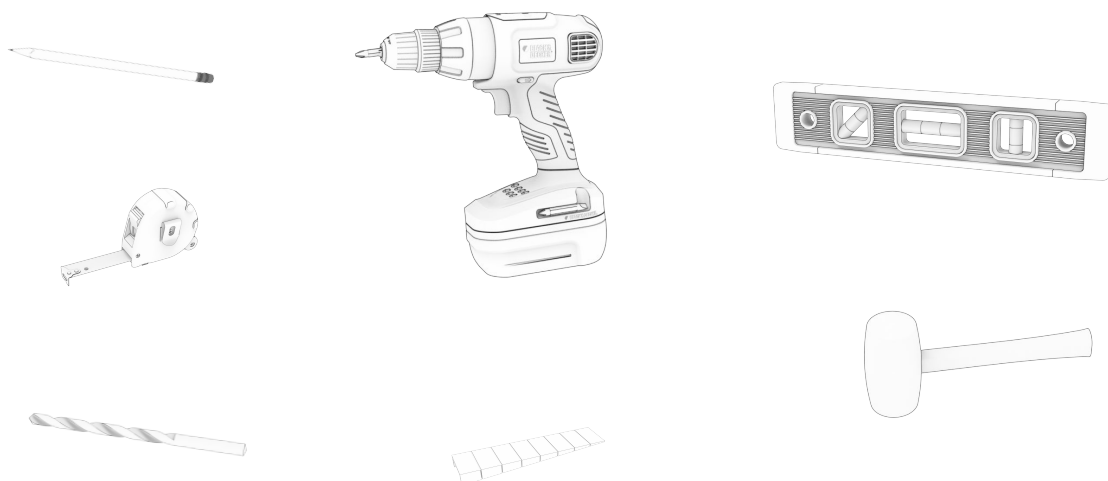

1 Take Inventory.

Locate your Parts List in the Design Guide.

The goal of this step is to make sure no parts are missing. If you find an issue, contact Customer Service using the information at the bottom of this page.

Go down the Components Section of the Parts List and check off items as you take inventory. Set aside any part whose label contains the term "Vertical" or "Fixed".

Did you order more than one design? To reduce packaging waste, product from different designs may be mixed in a single box. The box label will list which parts are contained inside each box.

2 Preparation.

Take to the install area:

- a) Any part whose label contains the term "Vertical" or "Fixed"
- b) The "Open First" box(es)
- c) Any additional boxes containing only hardware
- d) Tools
- e) Remove or cutaway sections of base moulding to ensure panels fit tightly to wall.
- f) Your enthusiasm!

3 Install hardware.

Refer to the correct Hardware Diagram in your Design Guide to select the correct verticals and see your hardware locations.

Lay first vertical onto protective cardboard. Install hardware per Hardware Diagram (use M20 Connecting on End Panels, use Double Cam Screw on Shared Panel). Flip vertical over and repeat for other side if necessary. Install hardware for all verticals in this PHASE.

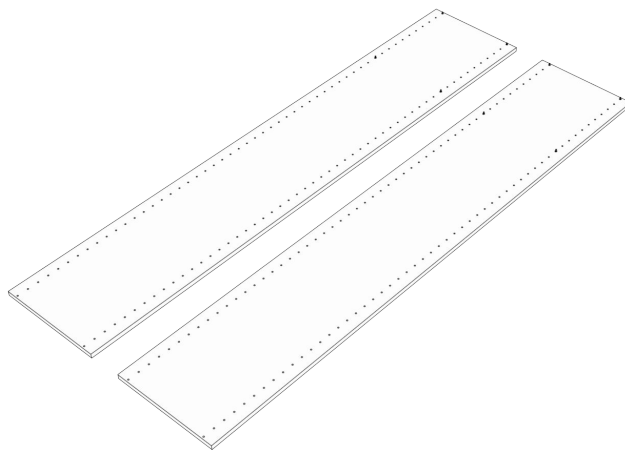
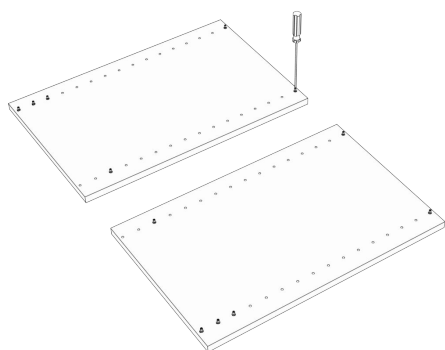

4 Place verticals.

Place verticals in approximate location per design. Start in corner if there is one.

Vertical panels and baseboard molding.

To accommodate your baseboard molding, you must either 1) remove it during installation, or 2) cut the vertical panels and possibly bottom fixed shelves.

Note: After installing your organizer, reinstall pieces of the molding in any areas not covered by the units.

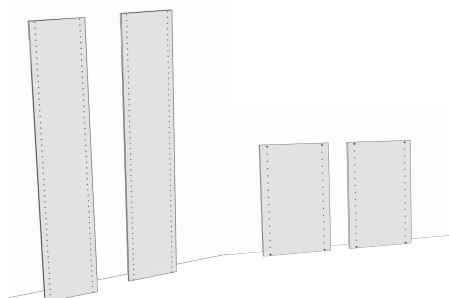

5 Install top fixed shelf onto first vertical.

Refer to the top of the Shelves and Cleats diagram in the Design Guide for shelf width. It is easiest if one person positions shelf onto cam screws while holding shelf level as the other person locks into place. Holding the Phillips screwdriver at a slight (15°) angle, lock fixed shelf with 1/4-1/2 turn of screwdriver. DO NOT FORCE.

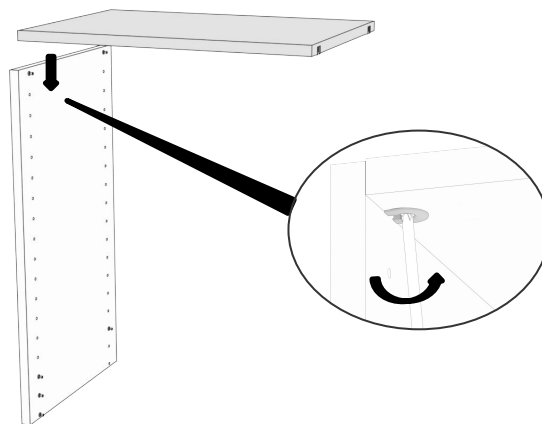

6 Install second vertical.

Move second vertical into fixed shelf. Lock other end of top fixed shelf to vertical.

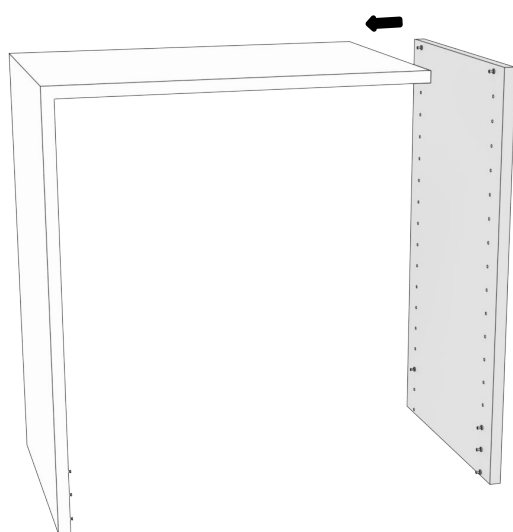

7 Place and Lock remaining fixed shelves according to the shelves and cleats diagram.

Note: Use small screwdriver for bottom shelf. Tighten back two cams first by tilting front of shelf up slightly.

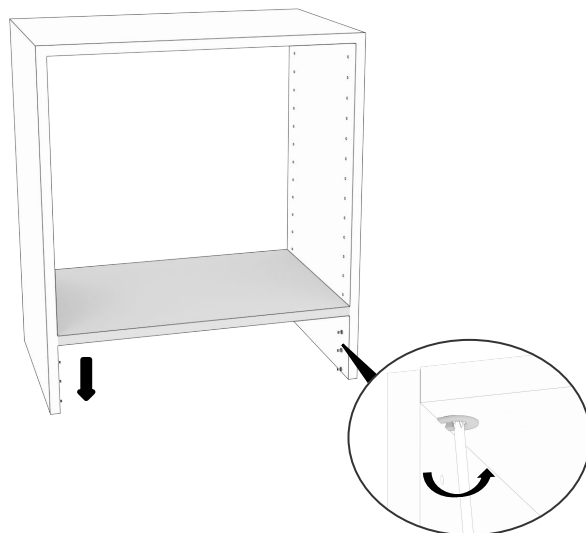

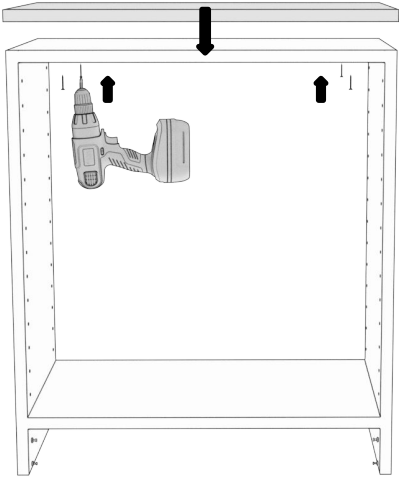
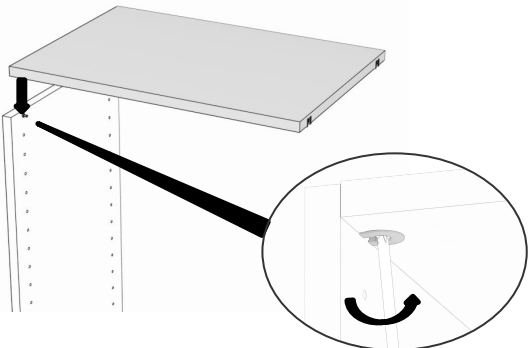
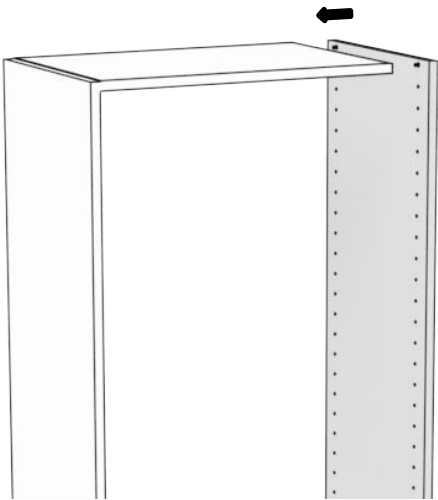
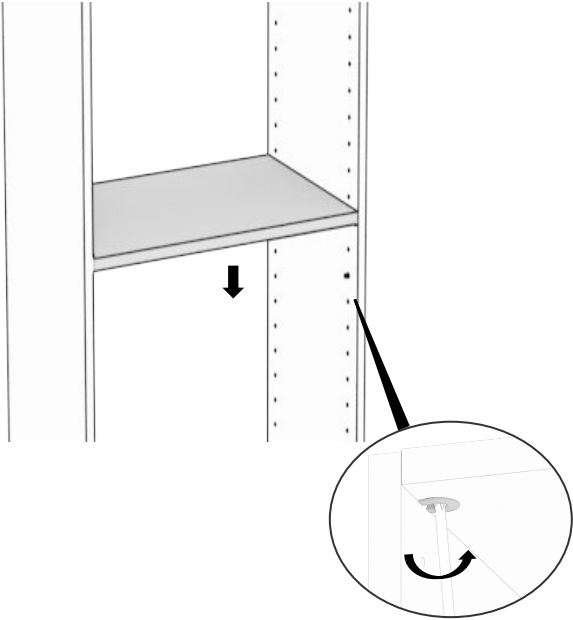
<p>8 Secure top (screw method only).</p> <p>Position top and hold firmly in place (clamp as needed). From underneath fasten with 1-1/4« screws until top is drawn tight to shelves.</p> 	<p>9 Install top fixed shelf onto first vertical.</p> <p>Refer to the top of the Shelves and Cleats diagram in the Design Guide for shelf width. It is easiest if one person positions shelf onto cam screws while holding shelf level as the other person locks into place. Holding the Phillips screwdriver at a slight (15°) angle, lock fixed shelf with 1/4-1/2/ turn of screwdriver. DO NOT FORCE.</p> 
<p>10 Install second vertical.</p> <p>Move second vertical into fixed shelf. Lock other end of top fixed shelf to vertical.</p> 	<p>11 Place and lock remaining fixed shelves.</p> 

12 Soft-Close Drawer Slides

Disconnect slide by pressing black tab and pull apart.

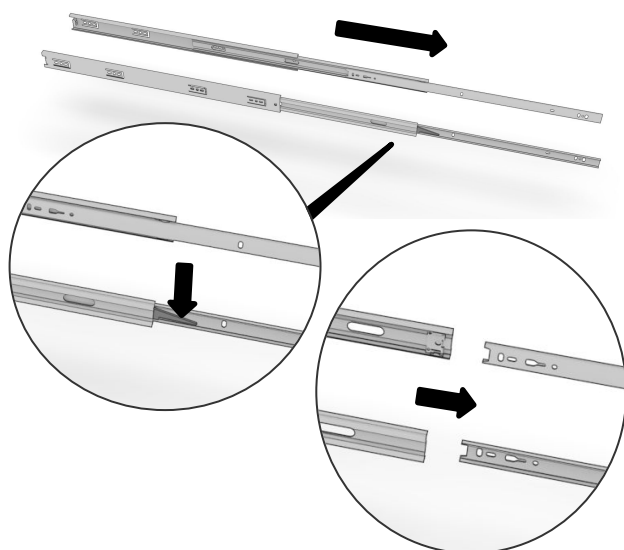

13 Soft-Close Drawer Slides (continued)

Place slide onto vertical with main body just back from finished edge of vertical a). Insert Euro screw into front hole b).

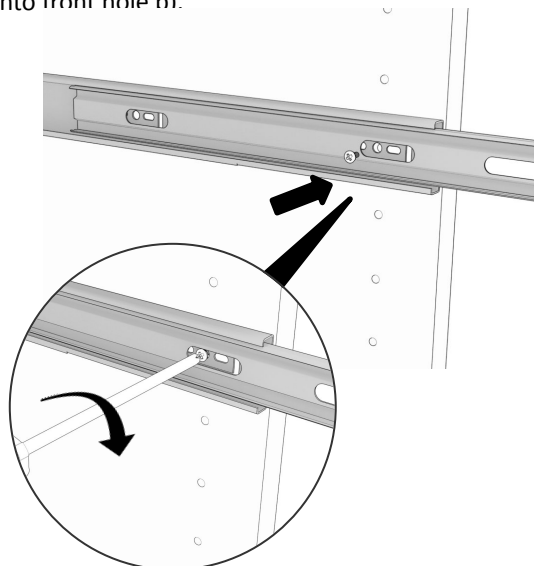

14 Soft-Close Drawer Slides (continued)

Insert 5/8" screw into middle set of slide holes. NOTE: This is not in a line bore hole. NOTE: The back line bore hole is NOT used with soft close slides. Use square for proper alignment.

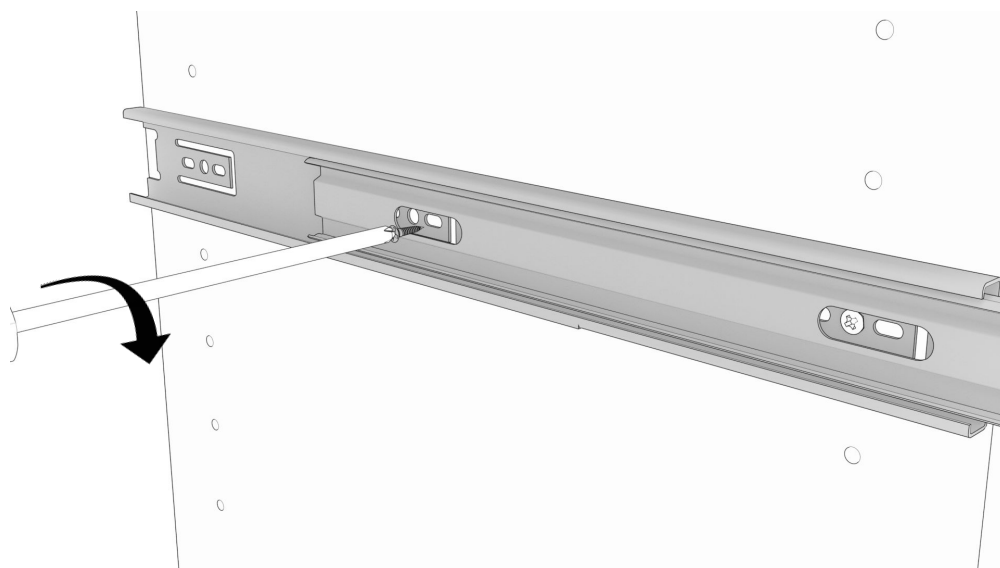

15 Install Standard Drawer Slides

Install Standard Drawer Slides (continued) Place slide onto vertical with main body just back from front edge of vertical. Secure using two (2) Euro screws.

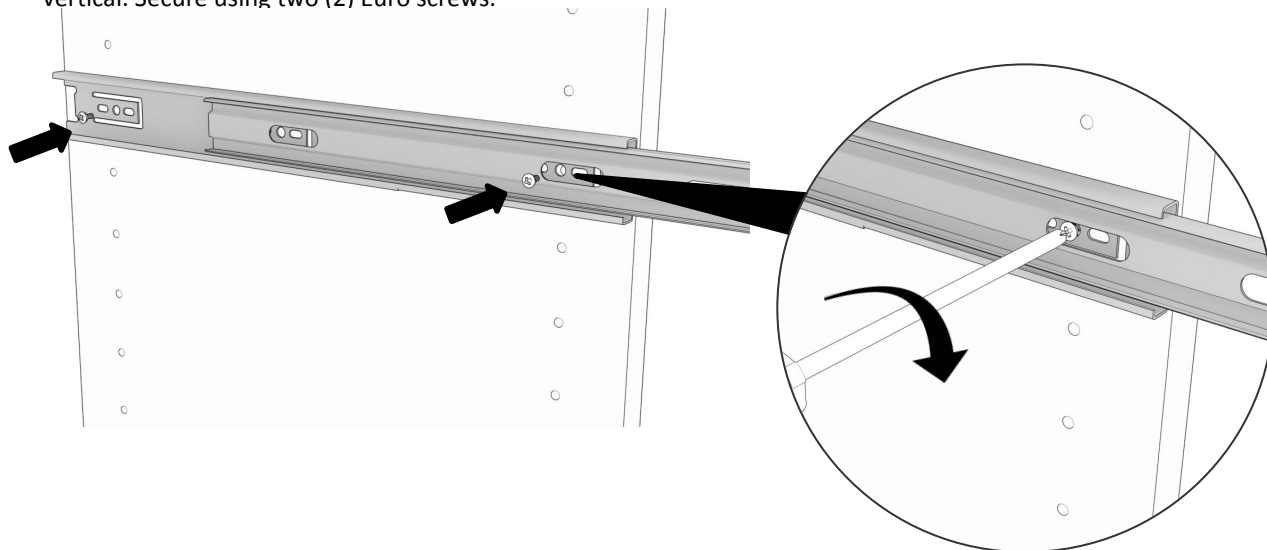

16 Insert pins.

Tap cylindrical pins into holes in sides. Use rubber mallet if needed.

Back



Front

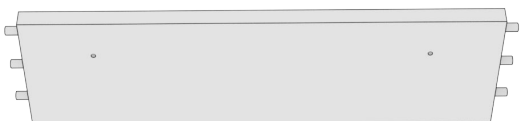

17 Attach.

Attach side of drawer box into place over the cylindrical pins.

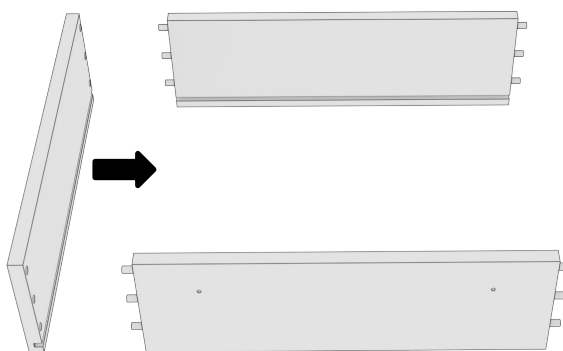

18 Attach bottom (continue).

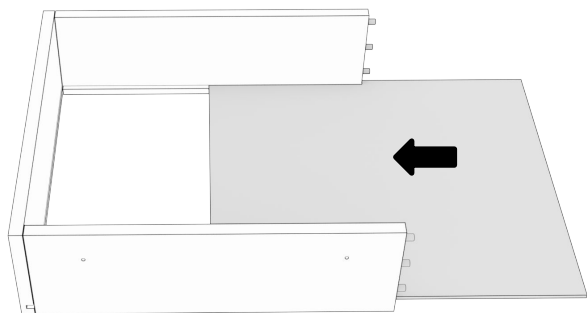

19 Attach (continue).

Use rubber mallet if needed.

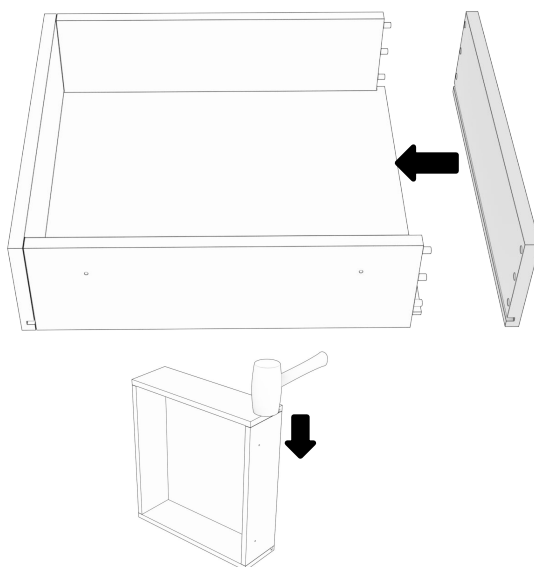

20 Locate and align.

The sides of the drawer box have dimples to help locate the installation location for the drawer slides. Align the drawer slide flush to the front edge of the drawer box. When properly aligned, the dimples are visible through holes near the front and back of the drawer slide.

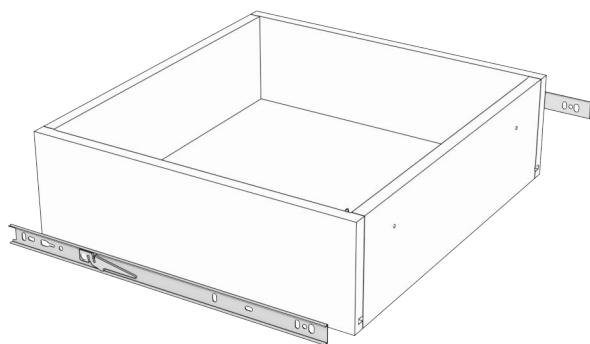

21 Attach.

Attach slide to drawer box using three (3) #6 x 1/2" screws on each side. The screws will go through the holes and into the dimples at the front and back of the drawer slide. The third screw can go into any of the holes near the middle of the slide.

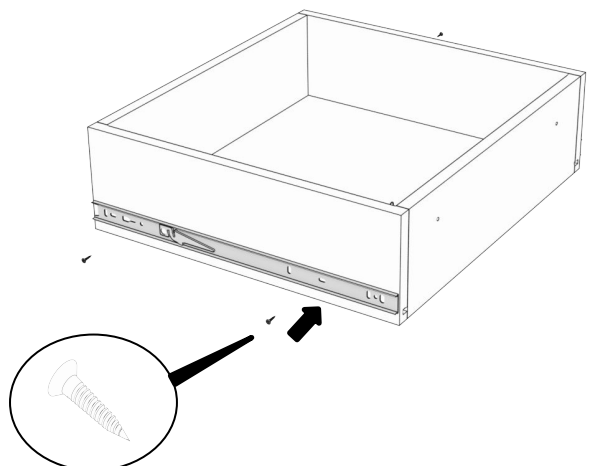

22 Attach handle/knob.

Drill for the knob or handle using a 5mm or 3/16« drill bit through the countersunk holes located on the back side of the drawer front. Using screws paired with handle or knob, attach to drawer front tightly through holes.

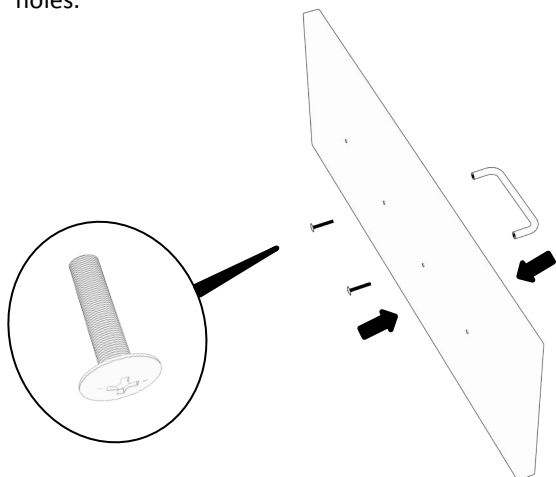

23 STANDARD method for attaching drawer fronts.

Using two (2) drawer front screws, attach front to box. Do not fully tighten. Use hand screwdriver only.

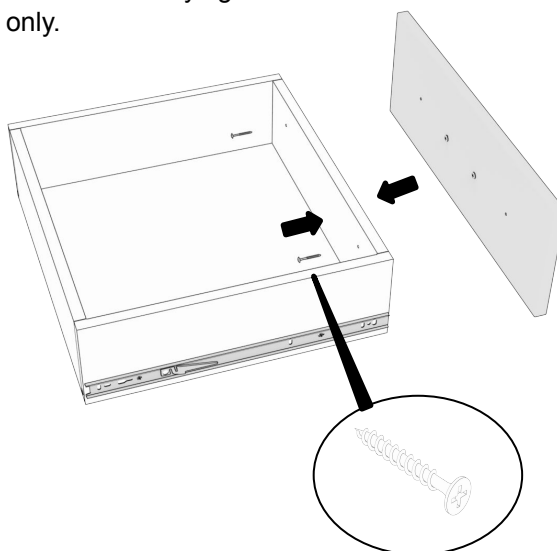

24 SHAKER method for attaching drawer fronts.

Pound drawer adjuster inserts flush into shaker front.

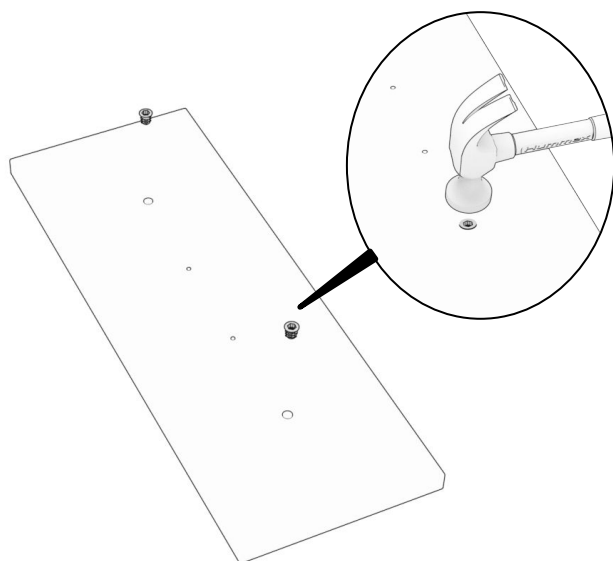

25 SHAKER method for attaching drawer fronts (continued).

Using two (2) drawer front screws and washer, attach front to box. Do not fully tighten. Use hand screwdriver only.

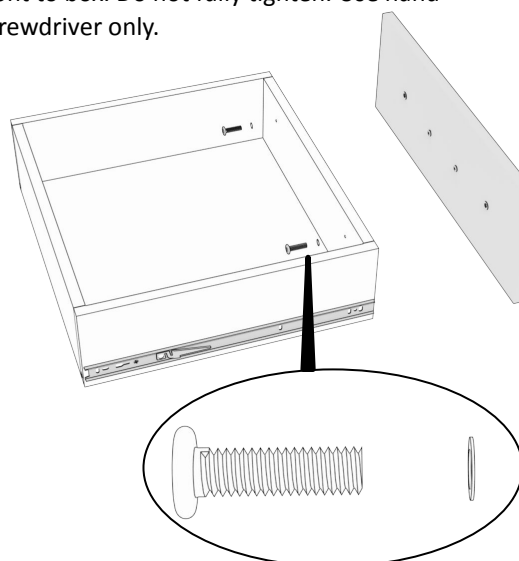

26 Install drawer in cabinet.

Push slides fully back.

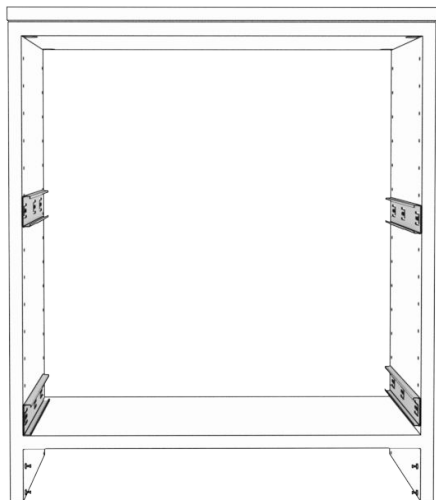

27 Install drawer in cabinet (continued).

Align drawer slide with cabinet slide. Gently press fully closed. Cycle drawer once to confirm.

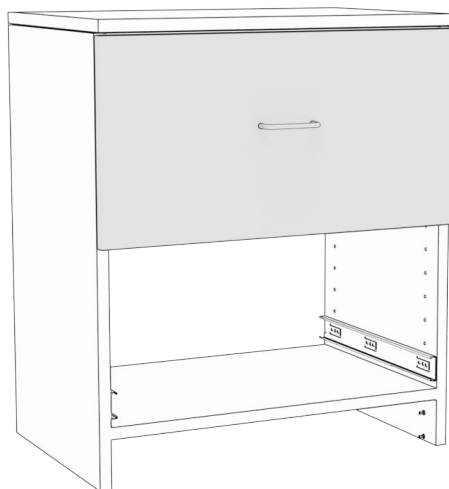

Repeat for remaining drawers.

28 Align fronts.

Align fronts. Starting with top drawer, using hand screwdriver, slightly loosen drawer front screws (inside drawer). Adjust fronts into level alignment. An 1/8" gap between drawers is typical. Retighten screws. You may need to go through this process more than once. Repeat for remaining fronts.

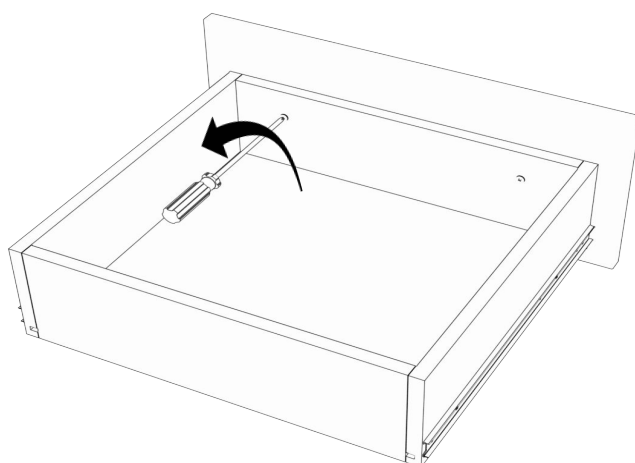

29 Install the lower section.

Install lower section, including the top, following the instructions provided for floor-based sections. This section is anchored to the wall with L-brackets.

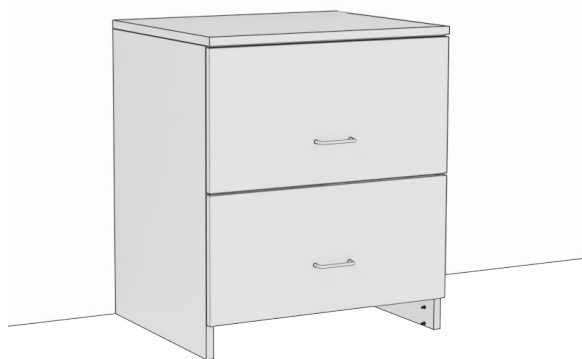

30 Install the upper section

Place a vertical panel for the upper section onto the lower section. Connect vertical panels with fixed shelves.

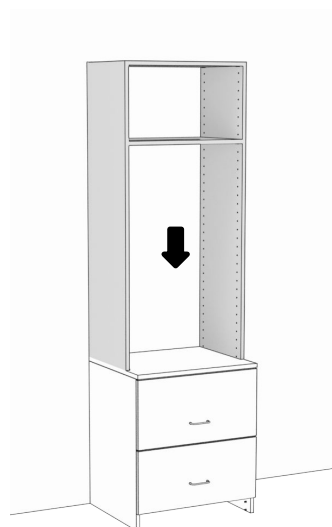

31 Level and square upper section.

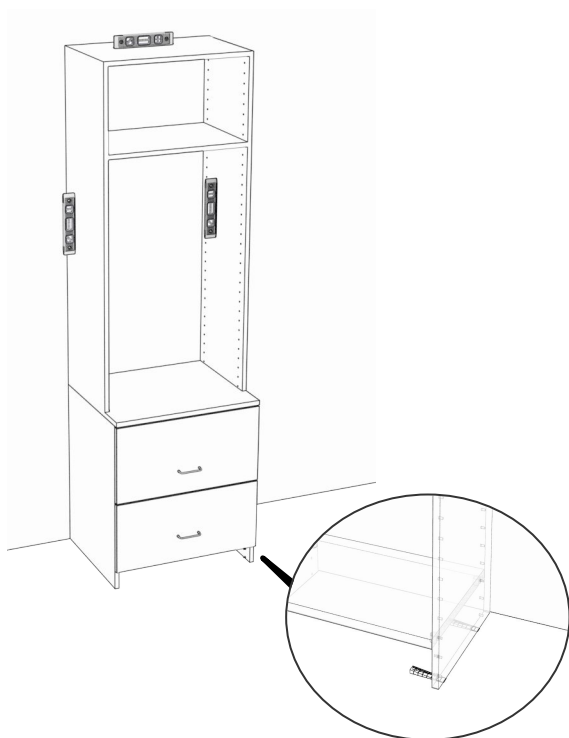

32 Slide toe kick under bottom shelf until it snaps into place.

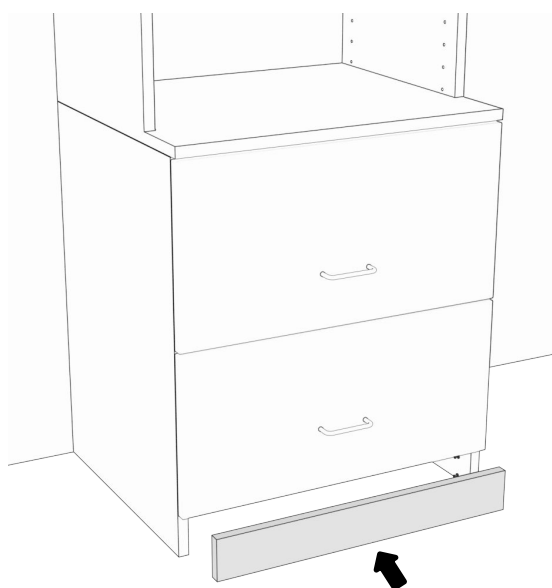

33 Anchor upper section with L-brackets.

Find studs with stud finder. Mark stud location with "X". Use two (2) 5/8" screws to attach L-bracket to shelf and one (1) 2" screw to attach L-bracket to wall at stud locations.

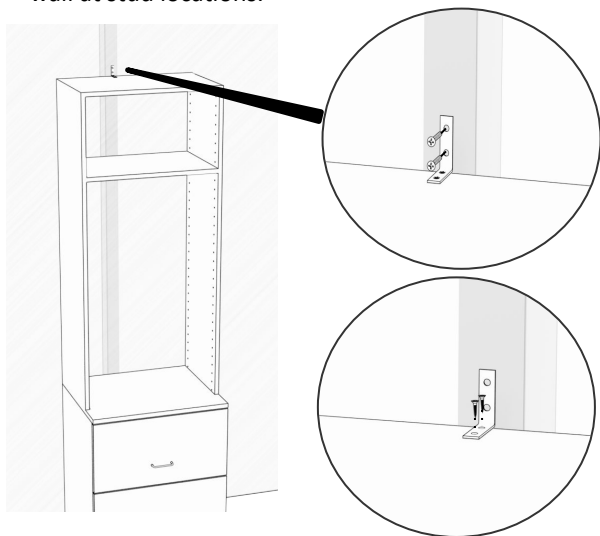

34 Install cleats.

Anchor the bottom of the upper section vertical panels with cleats. Use 2" screws to attach cleat to wall at stud locations. If design allows, place cleat directly below a fixed shelf to hide from view.

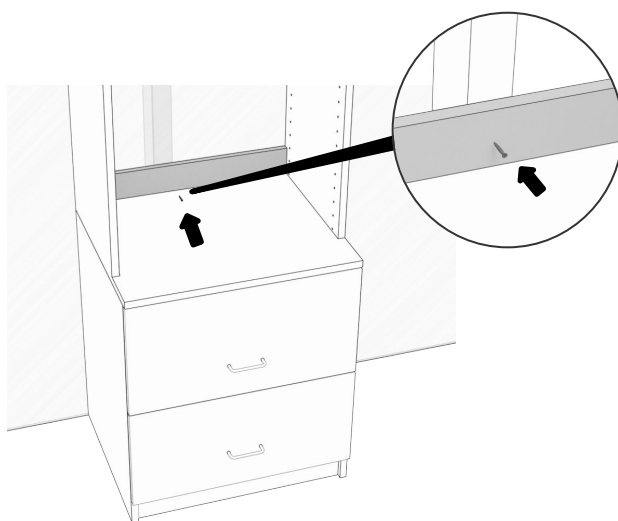

35 Add screw thru vertical from side into cleat to keep from shifting.

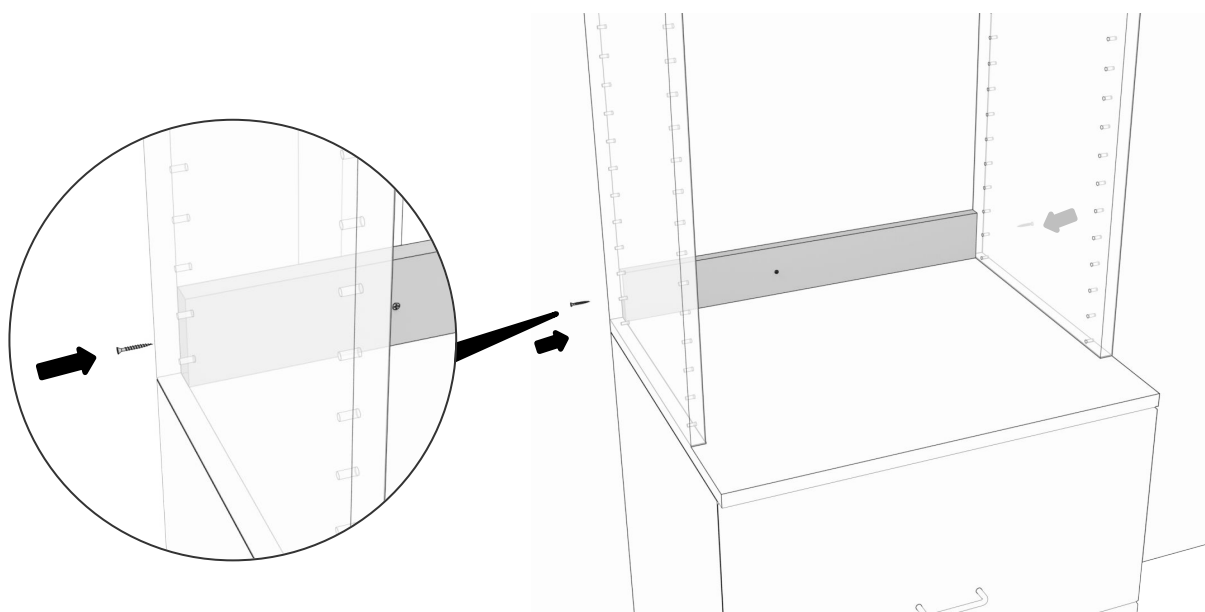

36 Drill and attach handle.

Using a 3/16" (5mm) drill bit, drill holes from face of door thru panel.

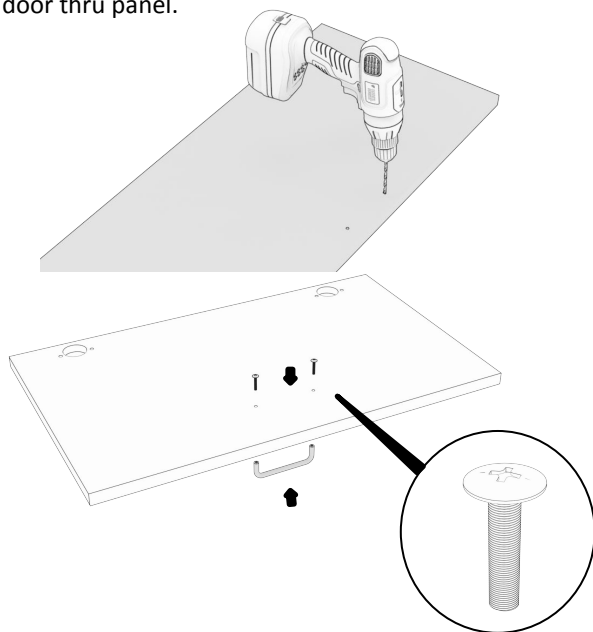

37 Attach hinges to door.

Using two (2) #6 x 5/8" screws, attach hinge cup to door.

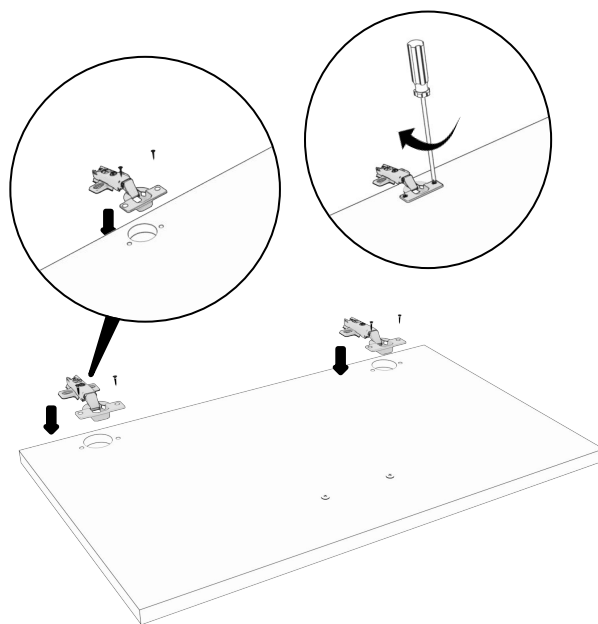

38 Attach hinges to closet.

The doors are half overlay doors. Hold door against the unit and position it so that the top and bottom cam shelves are partially covered by the door. The hinge plate should align with the front line bore holes.

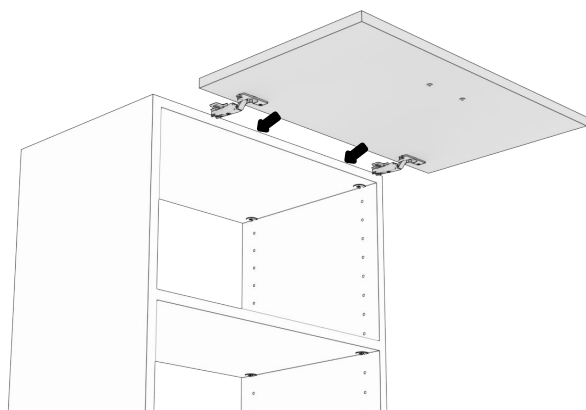

39 Attach door.

Attach hinge to vertical panel.

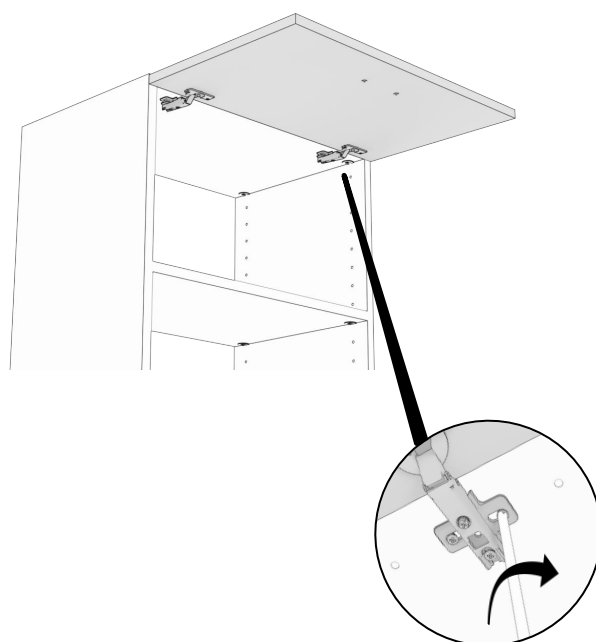

40 Adjust/align drawer front side to side.

Using a hand screwdriver, turn the screws to adjust drawer front to desired position.

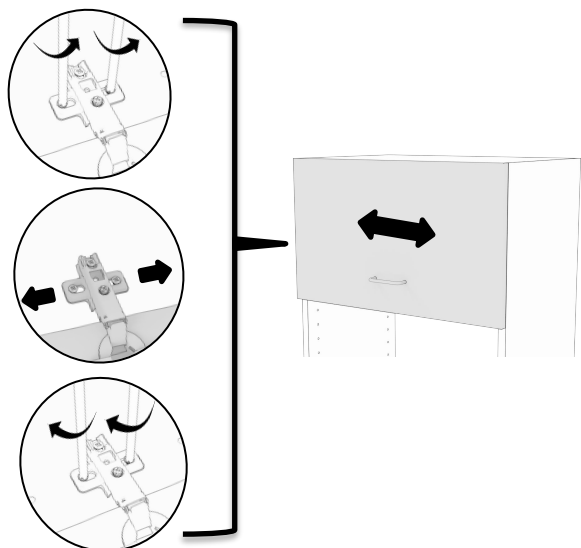

41 Adjust/align drawer front up and down.

Turn screws to adjust drawer front to desired position.

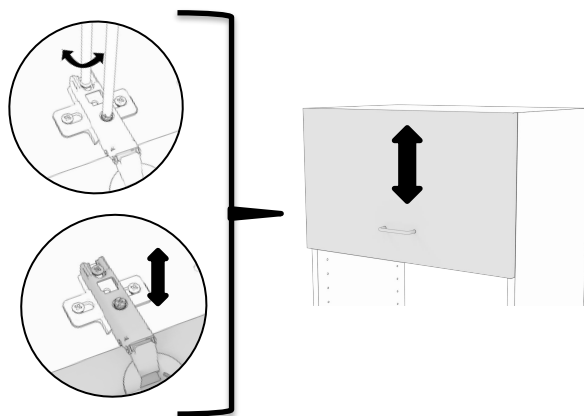

42 Adjust/align drawer front depth.

Turn screw to adjust drawer front to desired position.

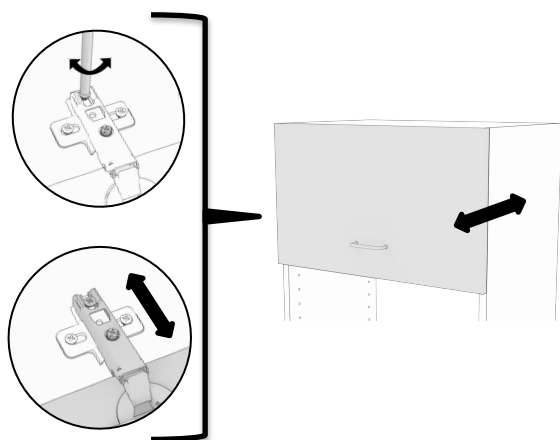

43 Attach lid stay/flap stay to closet.

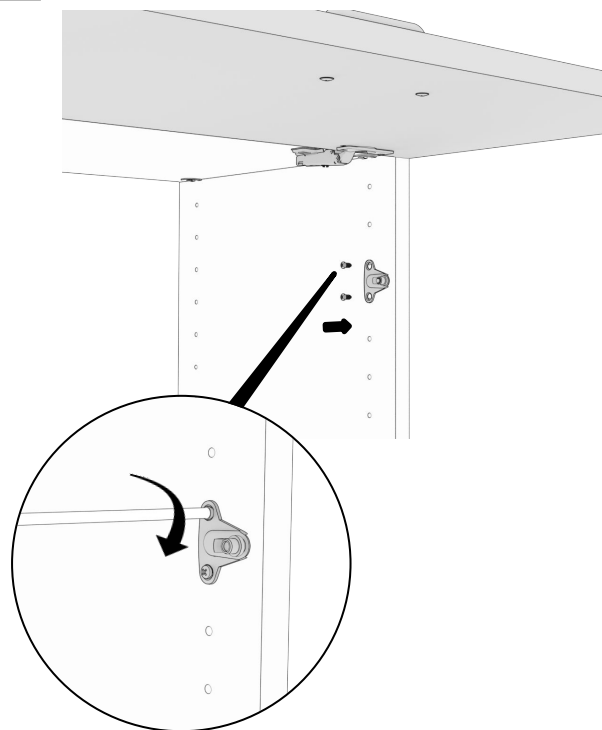

44 Attach lid stay/flap stay to door.

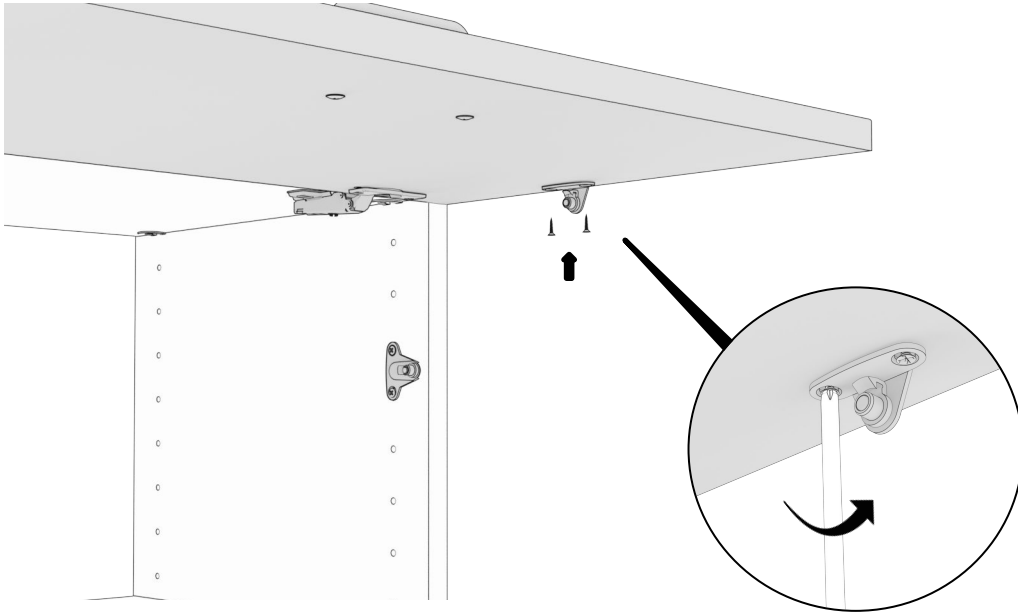

45 Assemble lid stay/flap stay.

Snap to lock together.

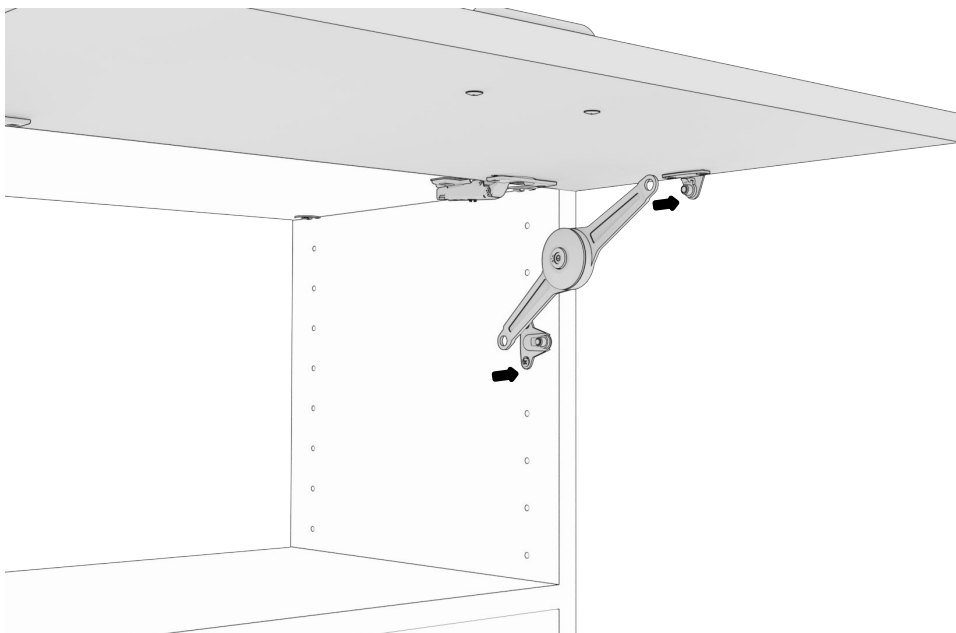

46 Adjust/align.

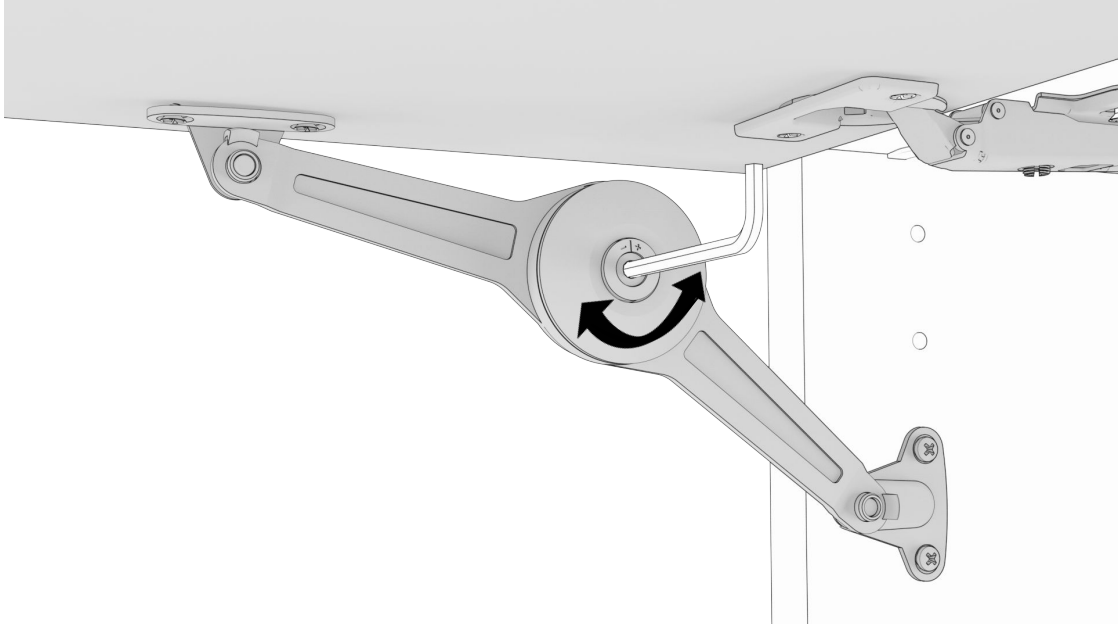

47 Disassemble lid stay/flap stay.

