

Levio Shelving +3 Drawers

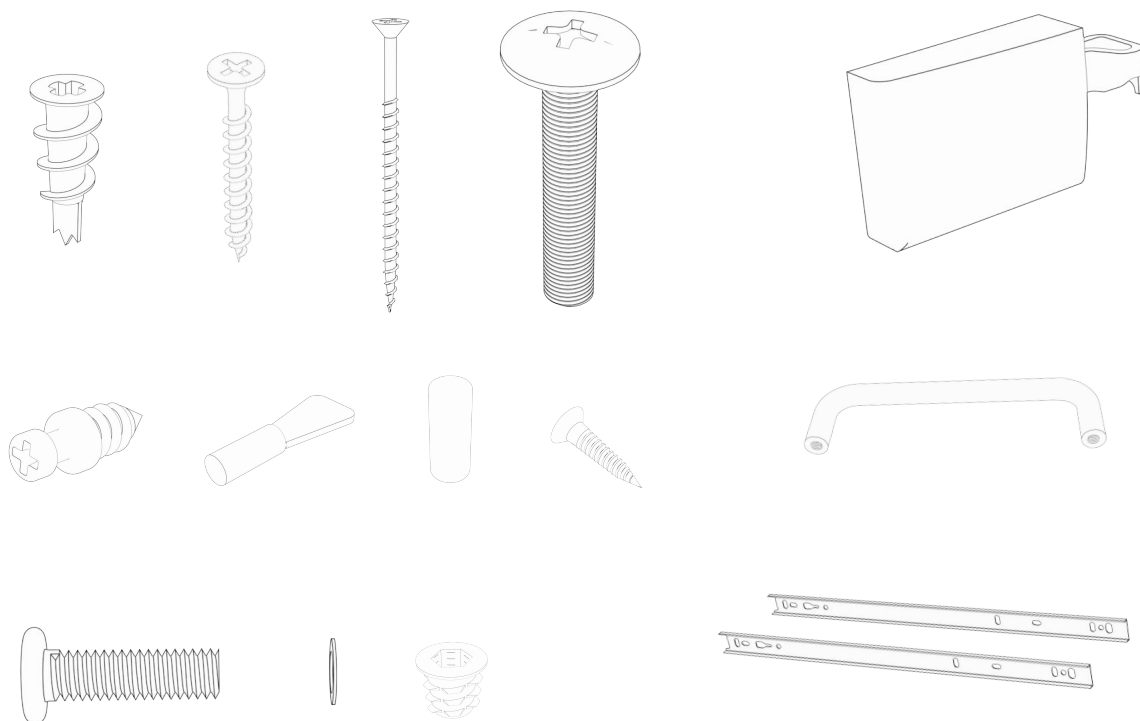

Assembly Hardware



Recommended Tools

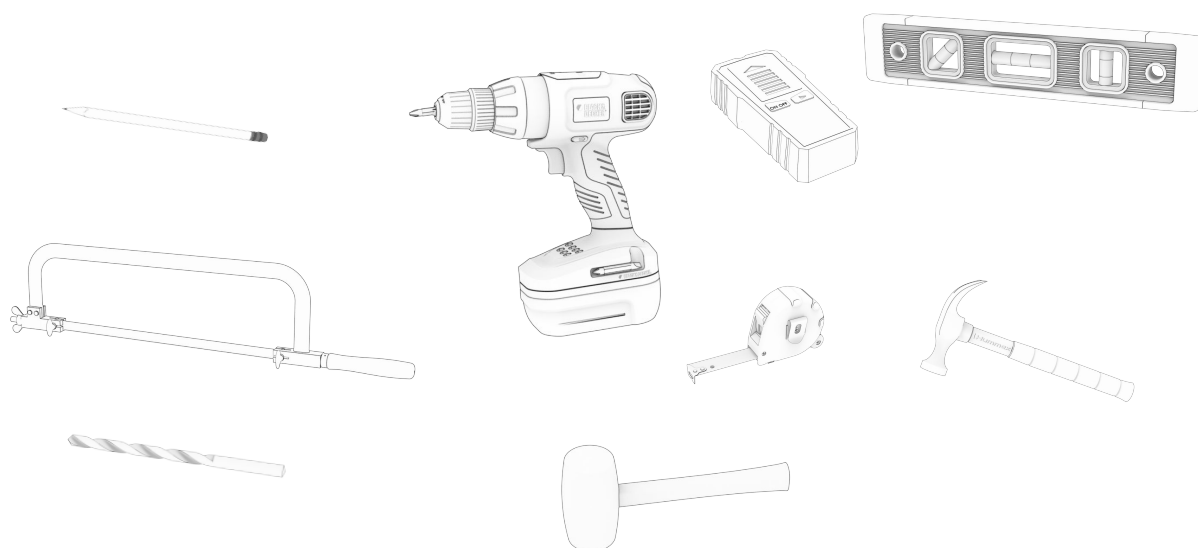

1 Take Inventory.

Locate your "Parts List" in the Design Guide.

The goal of this step is to make sure no parts are missing. If you find an issue, keep all packaging material and contact Customer Service using the information at the bottom of this page.

Go down the Components Section of the Parts List and check off items as you take inventory. Set aside any part whose label contains the term "Vert" or "Fixed".

Did you order more than one design? To reduce packaging waste, product from different designs may be mixed in a single box. The box label will list which parts are contained inside each box.

2 Preparation.

Take to the install area:

Take these items to the install area:

- a) Rails (often shipped in tubes)
- b) The "Open First" box(es)
- c) Any additional boxes containing only hardware or accessories
- d) Tools
- e) Your enthusiasm!

3 Cut Rails.

Refer to Install Rails page in Design Guide for rail lengths. Cut your rail(s) to length using a hacksaw.

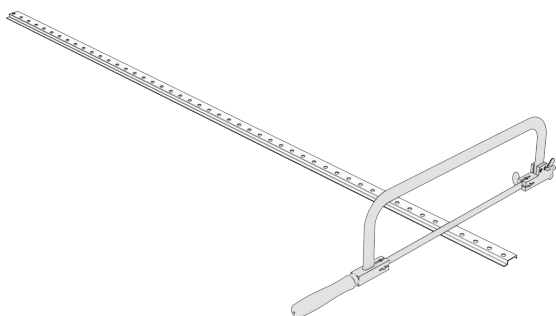

4 Position Rails.

Reference your 1 Distance From Floor and Distance from Wall measurements per your Install Rails Diagram in the Design Guide. Draw level line on wall.

NOTE: If you have mixed floor and hanging, install floor standing product first and use the 8-1/4" measurement from box 2 of the Install Mixed Floor and Hanging module to locate the rail height

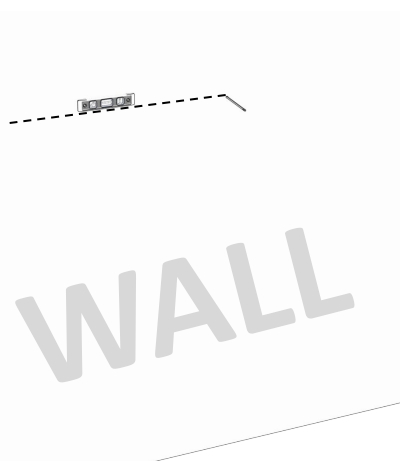

5 Pocket doors.

Draw level line for rail. Our standard toggles and rail screws are included with the order. When these cannot be used due to the space constraint of a pocket door, you must find and create support for the rail and the system.

You will need to use other types of drywall anchors and may be required to break off the points of an anchor to shorten its length. Use metal anchors for greater strength. Install anchor every 3' or as close as the manufacturer allows if no wood frame is found.

6 Locate studs.

Find studs with stud finder for all areas. Mark stud locations with "X" above line. Confirm stud location by driving small nail into wall just above line.

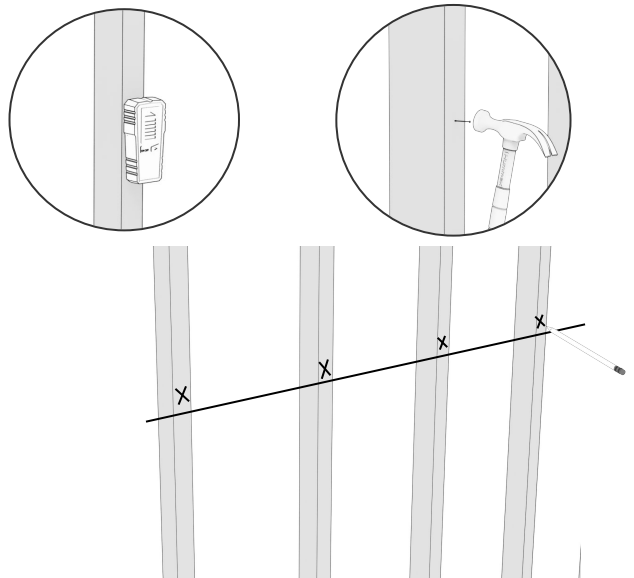

7 Locate vertical locations.

Refer to "Hardware Diagram" for each area to see vertical locations. Mark each vertical location with masking tape below line level.

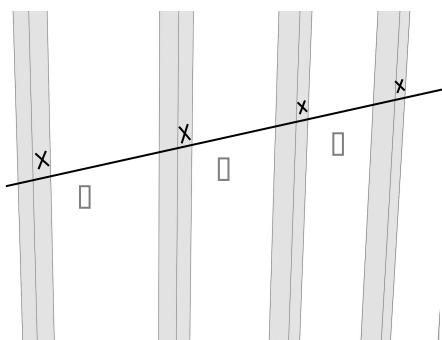

8 Place rail and mark toggle locations.

Hold rail to wall at line and at correct placement right to left. Mark all toggle locations through rail hole to wall.

Note: Do not put screws or toggles under a vertical.

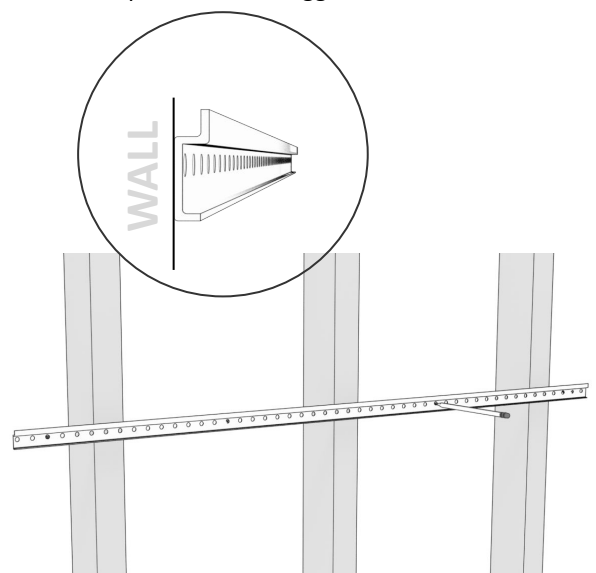

9 Determine toggle locations.

Toggles are required when:

- a) Vertical is more than 3" from a stud.
- b) Rail end is not on a stud.

IMPORTANT: Toggles only work with ½" or ⅝" thick drywall.

TIP: If wall has insulation which prevents toggle from engaging, drill ⅛" hole and use a small wire like hanger to push insulation back.

10 Install Toggles.

Loosen screw slightly. Install toggle ancho. Drive toggle into drywall until the flange is flush with the wall surface and arrows point up and down. Repeat at all marked toggle locations.

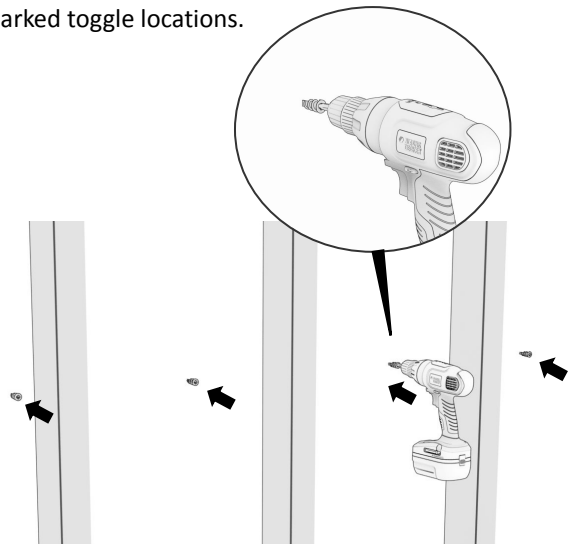

11 Install toggle screw with hand screwdriver.

Insert toggle screw by hand. Tap the end of the screw with your finger to fully pivot the clamp. Turn screw 20–25 complete revolutions to tighten. Do not overtighten or the drywall will be weakened.

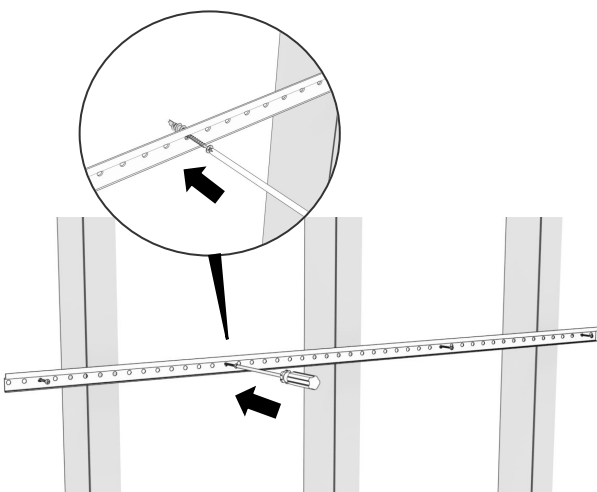

12 Drive rail screws into studs.

Use two (2) 2" rail screws per stud. Repeat steps for all rails in this design

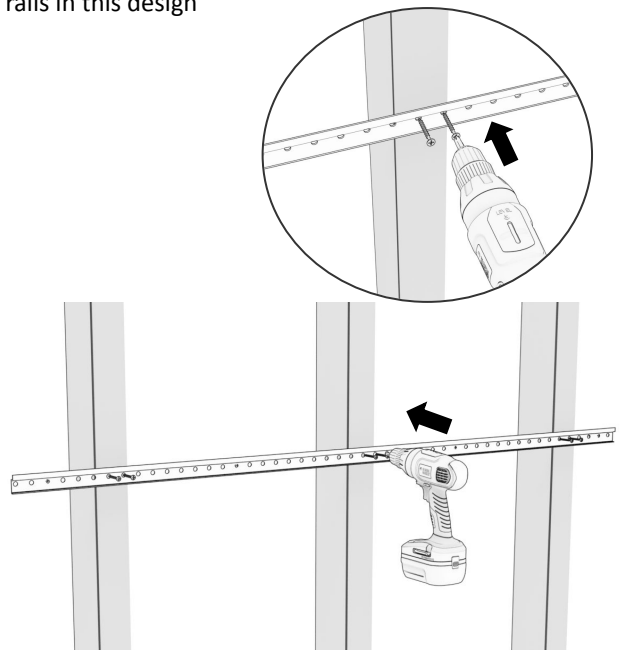

13 Make sure the rail is straight.

The rail must conform to the shelving system and not to an imperfect wall. Use a long straight edge, such as a 4 foot level to locate any hollows or bulges in the wall. Wherever the wall hollows, loosen the rail screws, insert shims between the rail and the wall and retighten the rail screws. Shims may be any solid, thin material.

Add shims behind rail to ensure it is straight.

IMPORTANT: Failure to shim the rail on a wavy wall will cause the vertical panel notches to break.

IMPORTANT: Do not install rail cover at this time.

14 Measure length.

Measure the interior measurements of each section

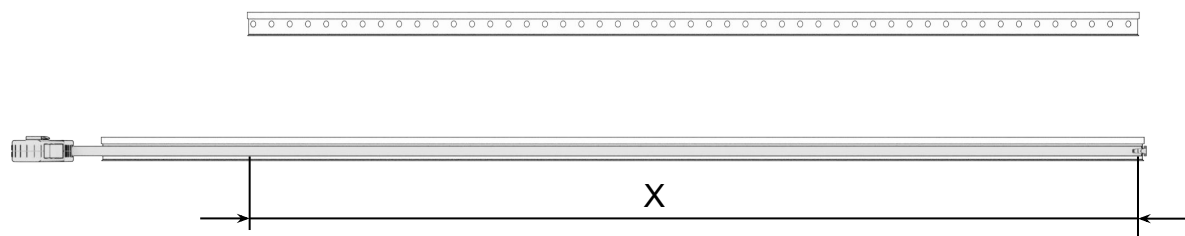

15 Cut to length.

Cut rail cover to length by marking the width, scoring with a utility knife and snapping in two while holding close to the score line a). Slip rail cover into place b).

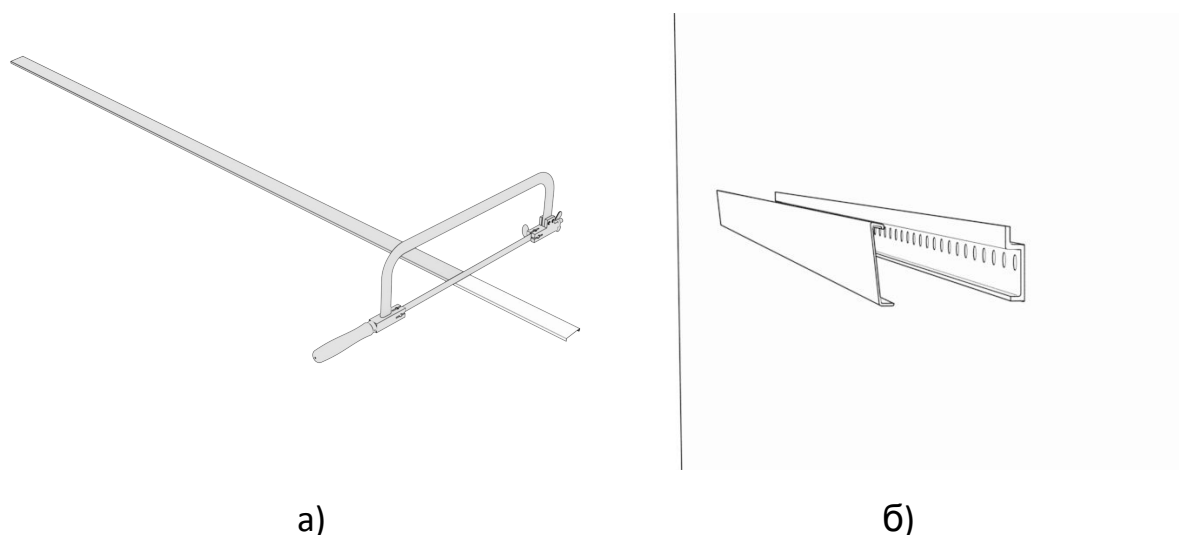

16 Install hardware (continued).

Lay first vertical onto protective cardboard. Install hardware per Hardware Diagram (use M20 Connecting on End Panels, use Double Cam Screw on Shared Panel). Flip vertical over and repeat for other side if necessary. Install hardware for all verticals in this PHASE.

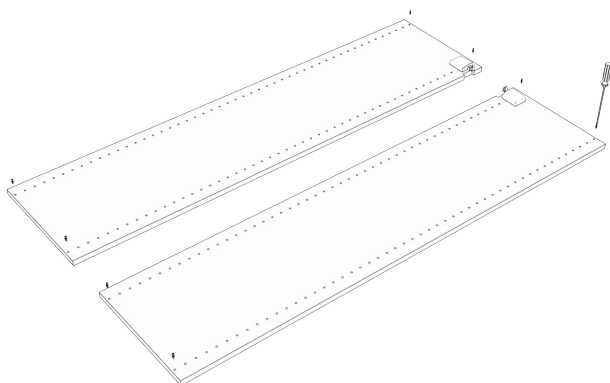

17 Finding a starting point.

Start working left to right if tight to left wall or centered on wall.

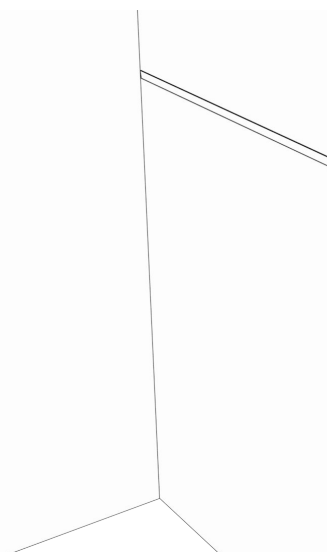

18 Place verticals onto rail.

Refer to the Design Guide and gently place first two (2) verticals onto the rail in the proper location over the masking tape. Remove masking tape from wall.

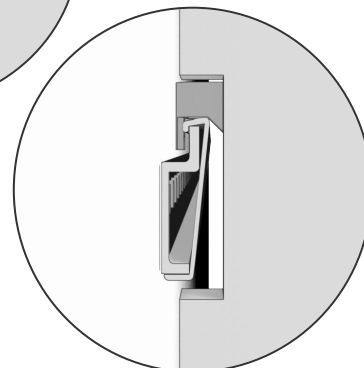
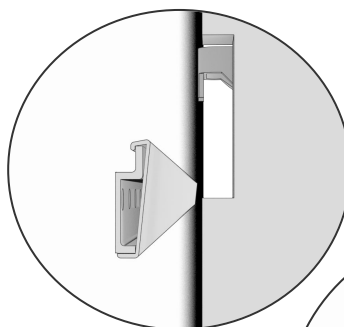
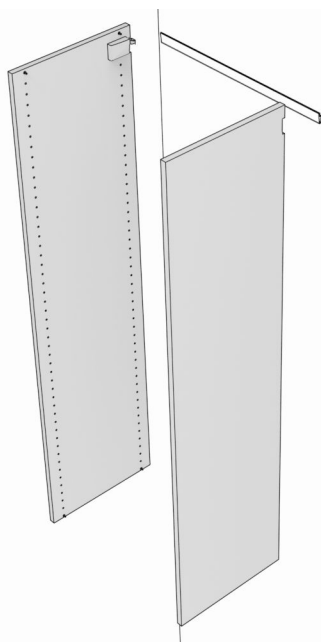

19 Install top fixed shelf onto verticals.

Refer to the Shelves and Cleats diagram in the Design Guide for shelf widths. Fixed shelves are identified by having four (4) cams, one in each corner. Install top shelf by placing onto cam screws. Holding Phillips screwdriver at a slight (15°) angle, lock fixed shelf with ¼ turn of screwdriver. DO NOT FORCE. Lock all four (4) cams

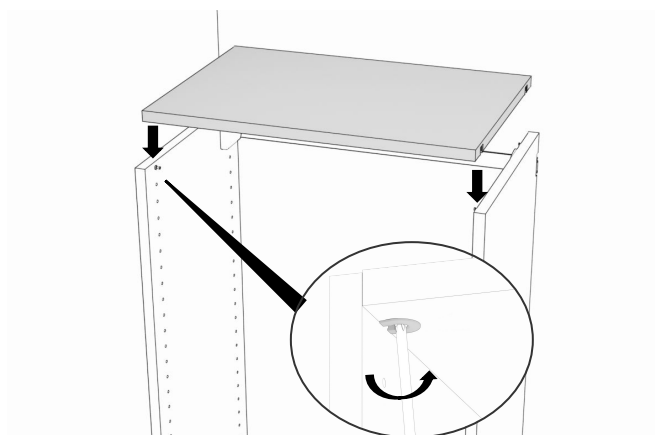

20 Place and lock remaining fixed shelves.

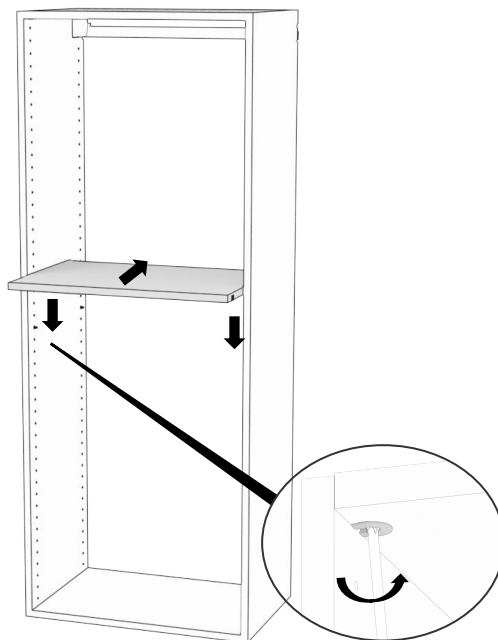

21 Soft-Close Drawer Slides

Disconnect slide by pressing black tab and pull apart.

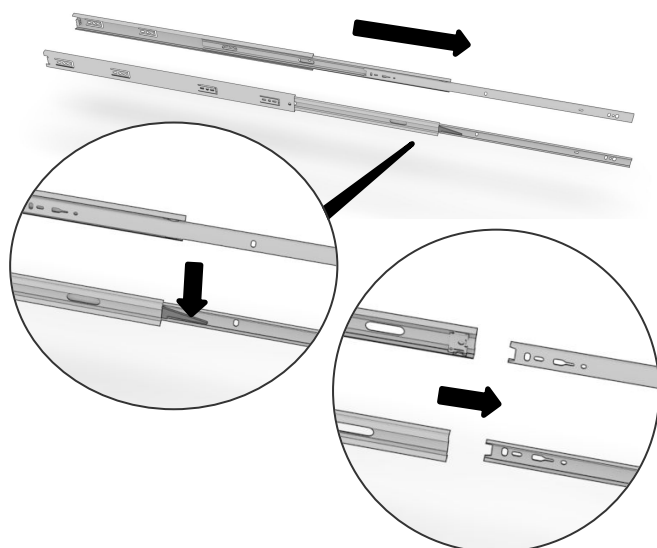

22 Soft-Close Drawer Slides (continued)

Place slide onto vertical with main body just back from finished edge of vertical a). Insert Euro screw into front hole b).

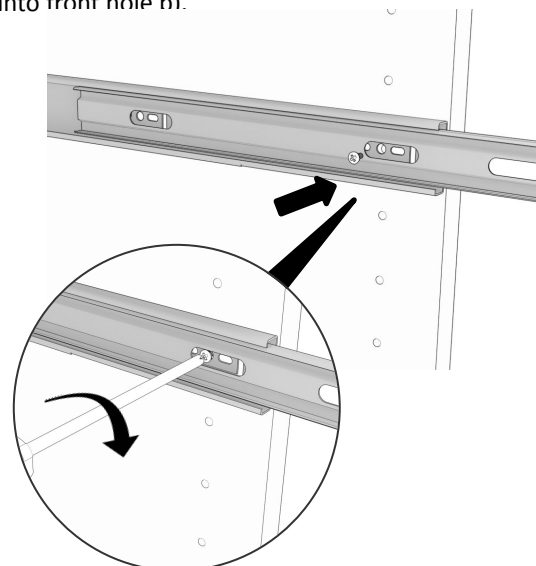

23 Soft-Close Drawer Slides (continued)

Insert 5/8" screw into middle set of slide holes. NOTE: This is not in a line bore hole. NOTE: The back line bore hole is NOT used with soft close slides. Use square for proper alignment.

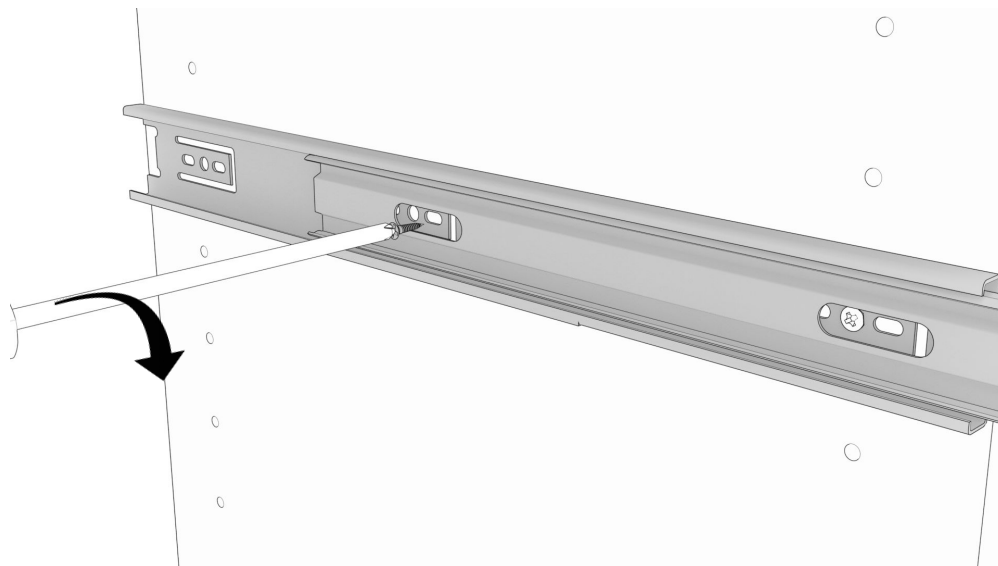

24 Insert pins.

Tap cylindrical pins into holes in sides. Use rubber mallet if needed.

Back



Front

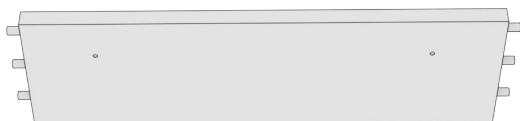

25 Attach.

Attach side of drawer box into place over the cylindrical pins.

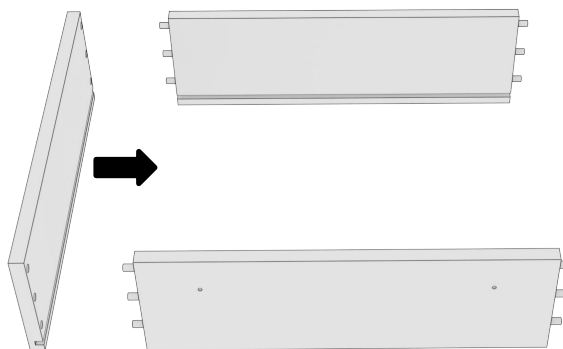

26 Attach bottom (continue).

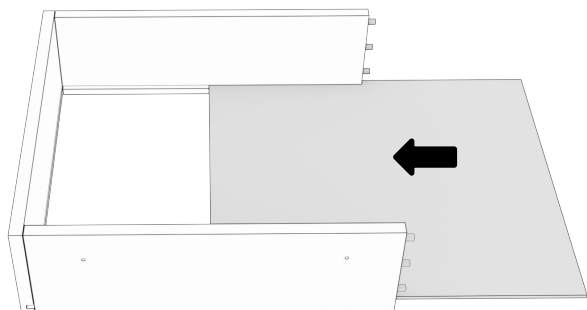

27 Attach (continue).

Use rubber mallet if needed.

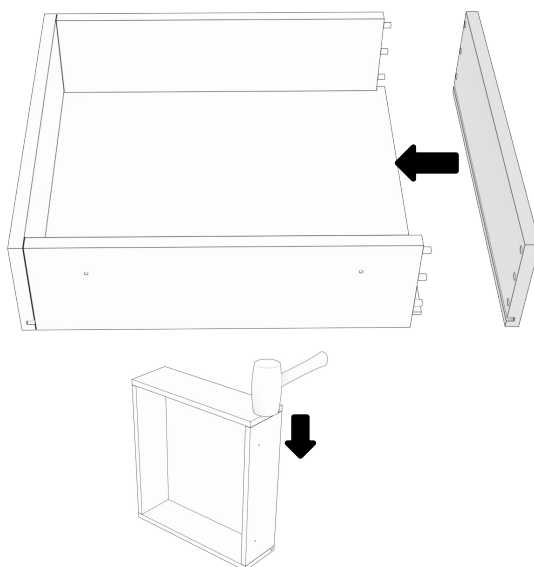

28 Locate and align.

The sides of the drawer box have dimples to help locate the installation location for the drawer slides. Align the drawer slide flush to the front edge of the drawer box. When properly aligned, the dimples are visible through holes near the front and back of the drawer slide.

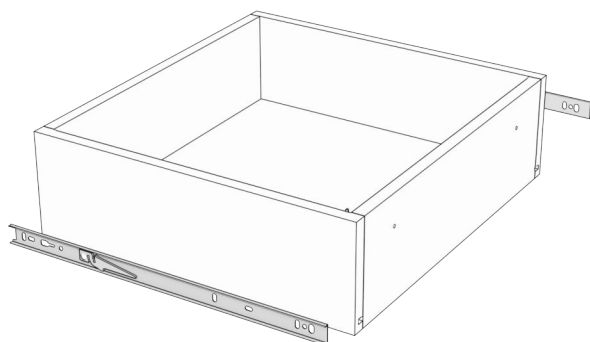

29 Attach.

Attach slide to drawer box using three (3) #6 x 1/2" screws on each side. The screws will go through the holes and into the dimples at the front and back of the drawer slide. The third screw can go into any of the holes near the middle of the slide.

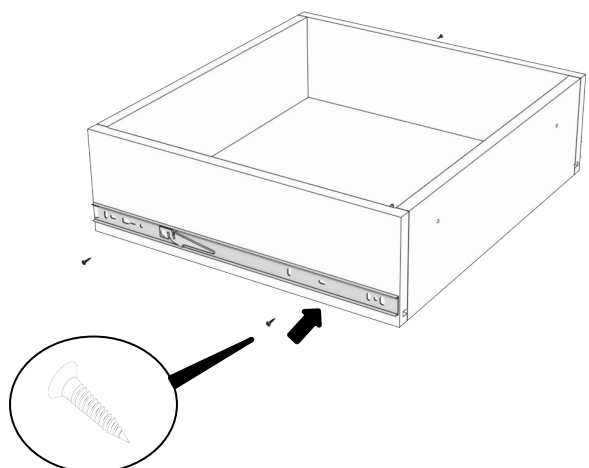

30 Attach handle/knob.

Drill for the knob or handle using a 5mm or 3/16« drill bit through the countersunk holes located on the back side of the drawer front. Using screws paired with handle or knob, attach to drawer front tightly through holes.

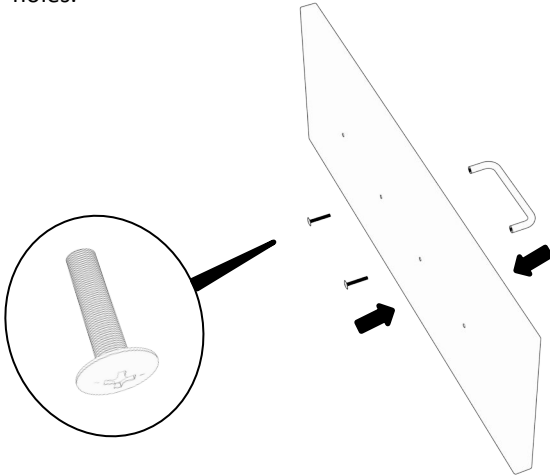

31 STANDARD method for attaching drawer fronts.

Using two (2) drawer front screws, attach front to box. Do not fully tighten. Use hand screwdriver only.

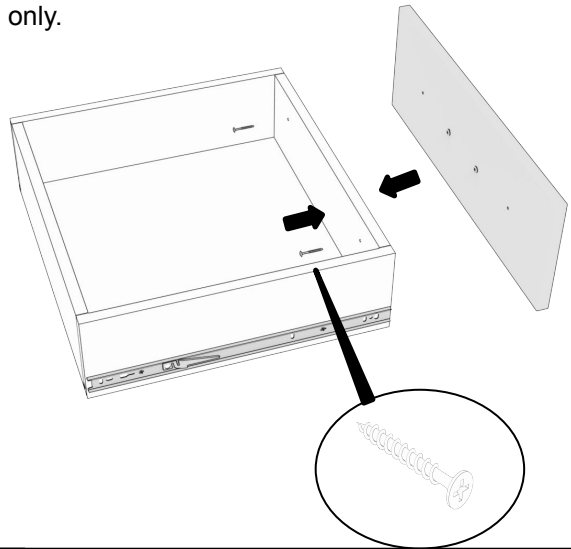

32 SHAKER method for attaching drawer fronts.

Pound drawer adjuster inserts flush into shaker front.

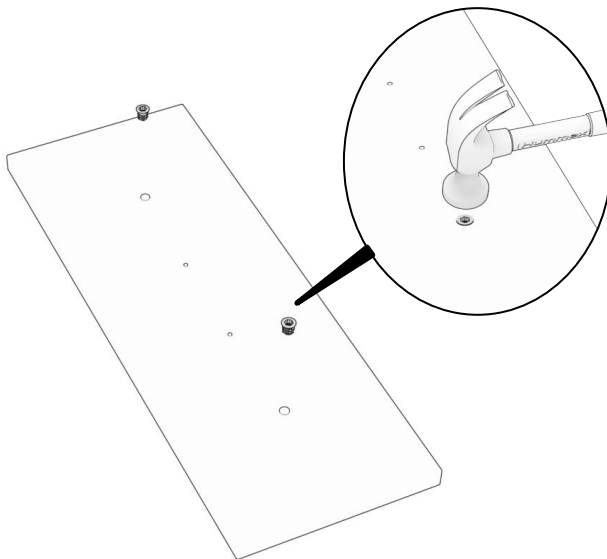

33 SHAKER method for attaching drawer fronts (continued).

Using two (2) drawer front screws and washer, attach front to box. Do not fully tighten. Use hand screwdriver only.

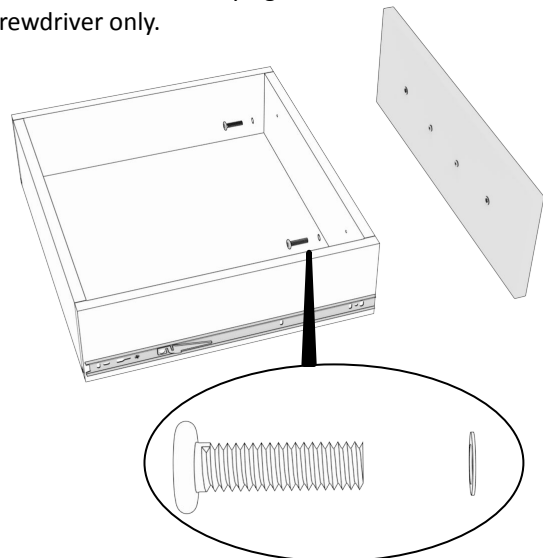

34 Install drawer in cabinet.

Push slides fully back.

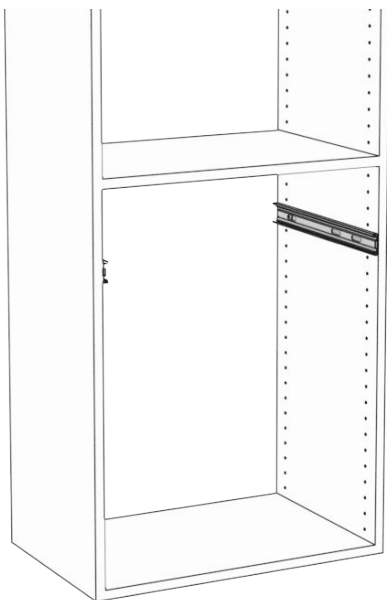

35 Install drawer in cabinet (continued).

Align drawer slide with cabinet slide. Gently press fully closed. Cycle drawer once to confirm.



Repeat for remaining drawers.

36 Align fronts.

Align fronts. Starting with top drawer, using hand screwdriver, slightly loosen drawer front screws (inside drawer). Adjust fronts into level alignment. An 1/8" gap between drawers is typical. Retighten screws. You may need to go through this process more than once. Repeat for remaining fronts.

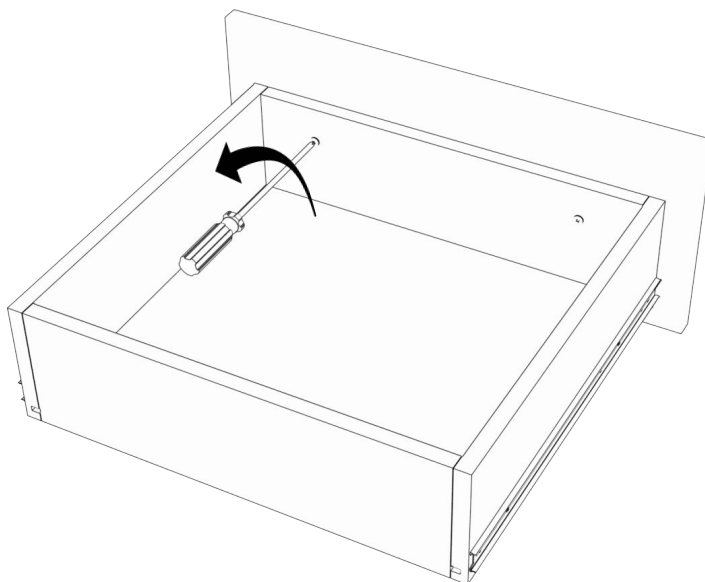

37 Install hardware.

Using the hole counting tape, install shelf pins at same height location in 4 places.

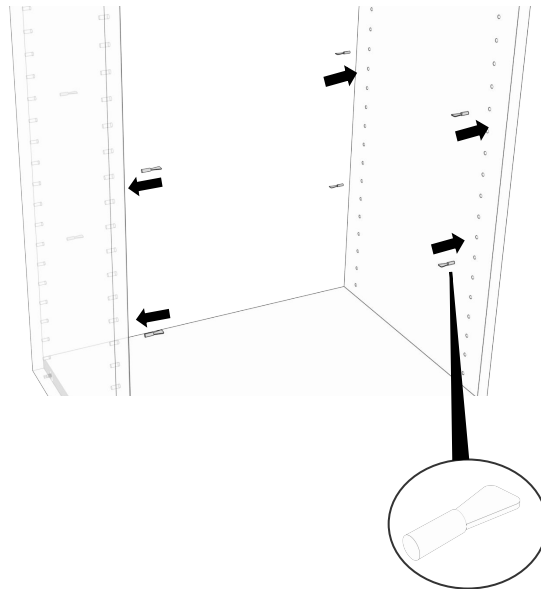

38 Place shelf on pins, finished edge facing out.

